

GRAB THE REINS ON 100 HORSES.

Rotax 912 ULS Specifications:

- 100 horsepower at 5,800 RPM
- 2,000-hour Time Between Overhaul (TBO)
- Four-cylinder/Four-stroke with liquid/air-cooling
- Dual carburetors
- Mechanical fuel pump
- Dry sump forced lubrication with separate oil tank with automatic adjustment by hydraulic valve tappet
- Electric starter
- Propeller speed-reduction unit

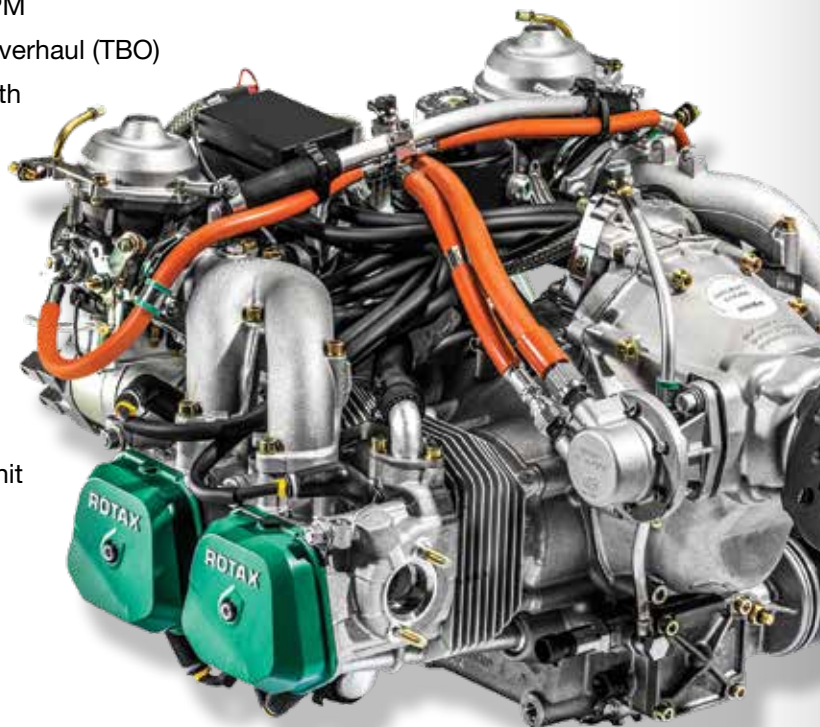

For more information contact:

Texas Aircraft Manufacturing
214-814-0934
1-800-922-2161
engage@TexasAircraft.com
www.TexasAircraft.com

Join the Texas Aircraft
posse on:



COLT[®]

Specifications

PERFORMANCE AND TECHNICAL SPECIFICATIONS.



PERFORMANCE AND TECHNICAL SPECIFICATIONS*

AIRCRAFT CERTIFICATION:

ASTM S-LSA

TYPE: Single-Engine Land Plane

SEATS: 2

PERFORMANCE SPECIFICATIONS:

ENGINE TYPE:

100 horsepower Rotax 912 ULS

PROPELLER TYPE:

Sterna composite, three-blade

MAXIMUM CRUISE SPEED:

118 knots

CRUISE SPEED AT 75% POWER:

110 knots

STALL SPEED CLEAN:

44 knots

STALL SPEED FULL FLAPS:

38 knots

MAXIMUM RANGE WITH TWO ADULTS AT 118 KNOTS:

572 nautical miles

With 30 minute reserve

MAXIMUM RANGE WITH TWO ADULTS AT 110 KTS:

607 nautical miles

With 30 minute reserve

TAKEOFF DISTANCE

(50 FOOT OBSTACLE):

1,085 ft (331 m)

LANDING DISTANCE

(50 FOOT OBSTACLE):

1,044 ft (318 m)

CLIMB RATE (VY):

800 ft /min at Vy

SERVICE CEILING:

14,500 feet

OPERATING WEIGHTS:

GROSS WEIGHT:

1,320 lbs (598 kg)

EMPTY WEIGHT:

835 lbs (379 kg)

USEFUL LOAD:

485 lbs (220 kg) with zero fuel

FUEL AND OIL CAPACITIES:

FUEL CAPACITY:

31.7 US gallons (120 l)

FUEL ECONOMY (AT 75% POWER):

4.9 US gal/h (18.5 l/h)

APPROVED FUEL TYPE:

100LL Avgas

OIL CAPACITY:

3.5 quarts (3 l)

EXTERIOR DIMENSIONS:

LENGTH:

23' 3" (7.1m)

HEIGHT:

7' 7" (2.3 m)

WINGSPAN:

32' 2" (9.8 m)

INTERIOR DIMENSIONS:

CABIN HEIGHT:

3' 8" (1.2 m)

CABIN WIDTH:

3' 6" (1.09 m)

SEAT WIDTH:

16" (0.4 m)

MAXIMUM BAGGAGE WEIGHT:

44 lbs (20 kg)

BAGGAGE AREA VOLUME:

38" x 22" (0.96 x 0.55 m)

SAFETY FEATURES:

- Welded chromoly steel safety cell
- All aviation-grade aluminum airframe
- Galaxy GRS ballistic parachute system**
- Hooker, four-point passenger safety harnesses
- Dynon SkyView HDX touchscreen with Synthetic Vision
- Dynon SkyView Two-Axis Autopilot with Level button**
- Docile flight characteristics
- Slow stalling speed

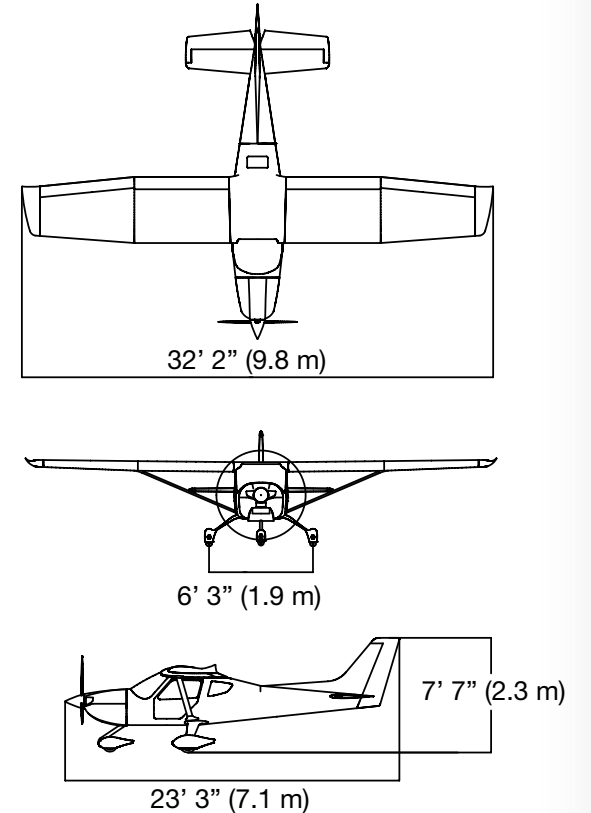

*All features and specifications are subject to change without notice.

**Airframe parachute and autopilot are standard on the Colt-SL and optional on the Colt-S.